

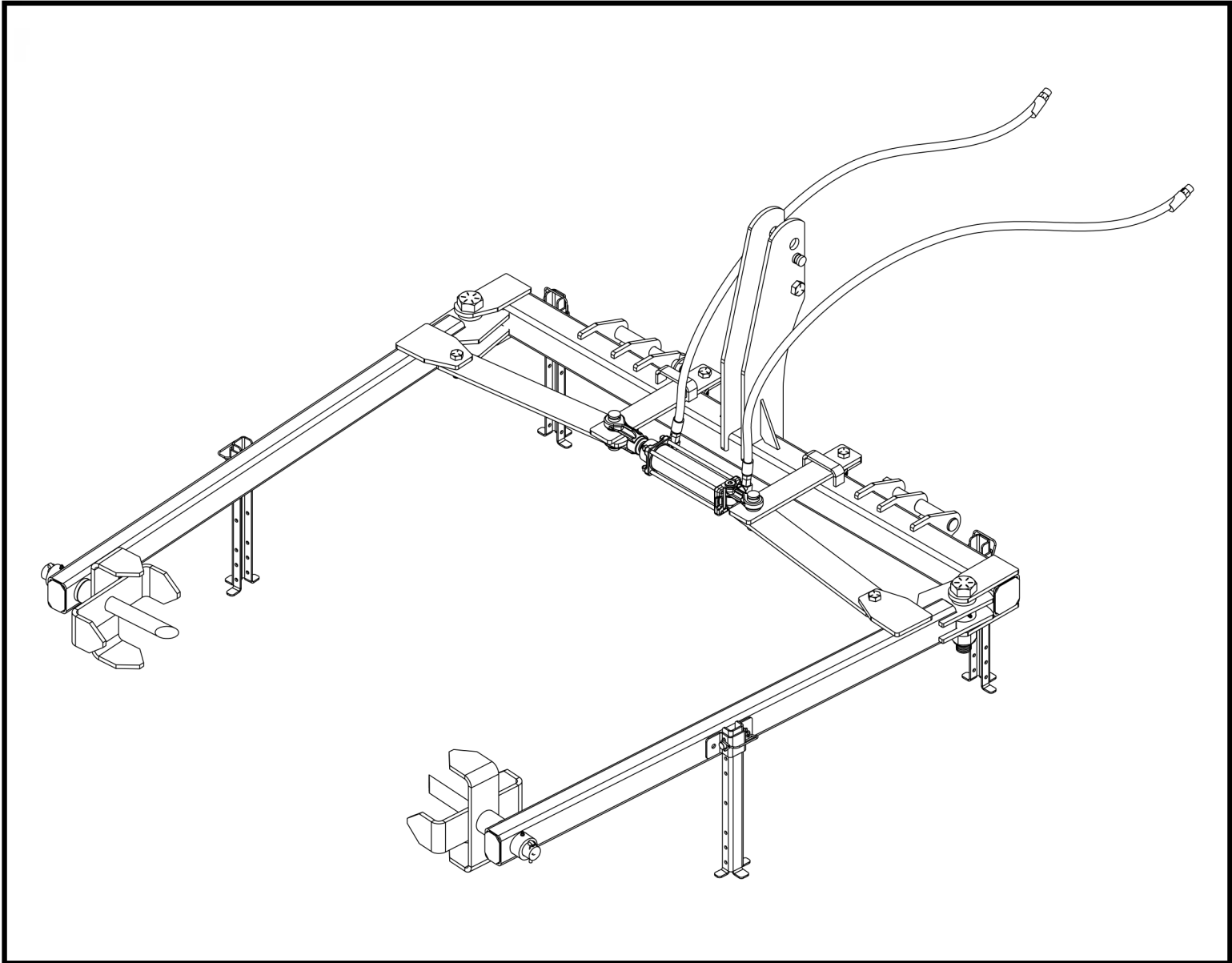

# Hay Bale Unroller

## Operator Manual





## Table of Contents

---

---

<b>Product Introduction</b> . . . . .	<b>1</b>
<b>Safety Information</b> . . . . .	<b>2</b>
<b>Safety Decals</b> . . . . .	<b>5</b>
<b>Technical Information.</b> . . . . .	<b>6</b>
<b>Replacement Parts</b> . . . . .	<b>7</b>
<b>Grease Points</b> . . . . .	<b>8</b>
<b>Torque Information</b> . . . . .	<b>9</b>
<b>Warranty Information</b> . . . . .	<b>10</b>

**Serial #**



Homestead Implements is proud to have you as a new owner of one of our high-quality tractor implements. This Hay Bale Unroller has been expertly designed and hand-built by skilled American workers with only quality materials. With proper assembly, safe operating practices, and routine maintenance you will get years of effective use from this implement.

### **Product Description**

Homestead Implements Hay Bale Unrollers are engineered for consistent and repeated use. Our Hay Bale Unrollers are Quick-Hitch and iMatch compatible and are perfect for tractors up to 50 HP. The Hay Bale Unroller is a valuable attachment for moving and unrolling round bales.

### **Using This Manual**

This Homestead Implements Operator's Manual is designed and written to help familiarize the operator with assembly, operation, adjustments, troubleshooting, maintenance, and safety. Read this manual and follow the recommendations to help ensure safe and efficient operation.

All information in this manual was current at the time of printing and some parts may change to assure you of the best performance. Visit website for updated manual.

### **Owner Assistance**

The Homestead Implements 12-Month Limited Warranty (See Page 10) is active upon delivery. Keep all documents provided at delivery to provide you with quality customer service.

All parts on your Hay Bale Unroller should only be replaced with Homestead Implements parts. Contact Homestead Implements, or Jamestown Advanced Products, if repair parts are required.

### **Serial Number Location**

Please refer to the below image for quick reference to find the serial number and model number on your Homestead Implements product. When communicating to Homestead Implements with regard to repair or warranty claims, your model number and serial number are exceptionally important.

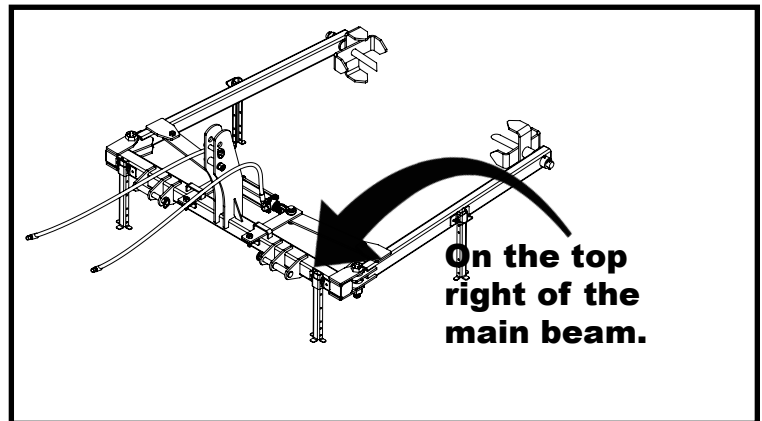

### **Additional Assistance**

Homestead Implements wants you to be extremely satisfied with your new Hay Bale Unroller. If you, for any reason, do not understand any part of this manual or are not satisfied with the service received, please consider the following actions:

If problems arise with the implement, contact Homestead Implements directly so they can address the problem.

Customer Service Representative:  
1-833-625-0635

For further assistance email:  
[sales@homesteadimplements.com](mailto:sales@homesteadimplements.com)

For further assistance write to:  
Homestead Implements  
ATTN: Jamestown Advanced Products  
2855 Girls Road, Jamestown, NY 14701

**BE AWARE OF THE  
SAFETY ALERT  
SYMBOL**

The SAFETY ALERT SYMBOL indicates potential hazards to personal safety and extra safety precautions must be taken. When you observe this symbol, be alert and carefully read any messages that follow it. In addition to design and configuration of the equipment, hazard control, and accident avoidance are dependent upon the awareness, caution, and proper training of personnel involved in the operation, maintenance, transportation, and storage of equipment.

**Be Aware of Signal Words**

A signal word designates a degree or a level of hazard seriousness. The signal words are:

- ⚠ **Danger** – Indicates a hazardous situation that, if not avoided, will result in serious injury or death.
- ⚠ **Warning** – Indicates a hazardous situation that, if not avoided, could result in serious injury or death.
- ⚠ **Caution** – Indicates a hazardous situation that, if not avoided, could result in minor to moderate injury.

**TRACTOR SHUTDOWN  
& STORAGE**

- If engaged, disengage PTO, park machine and implements on solid, level ground and lower implement to the ground or onto additional support blocks.
- Put tractor in park or set park brake, turn off the engine, and remove switch key to prevent any unauthorized starting.
- Relieve all hydraulic pressure to auxiliary hydraulic lines.
- Do not leave the operator's seat until all components have stopped.
- Use steps, grab-handles, and anti-slip surfaces when stepping on and off the tractor.
- Detach and store implement in an area where children do not normally play. Secure the implement using blocks, supports, or wedges.

**SAFETY PRECAUTIONS  
FOR CHILDREN**

Tragedy and injury can occur if the operator is not alert to the presence of children.

- Keep all children out of the work area and under the watchful eye of a responsible adult that is not the operator of the equipment.
- Be alert and turn off the implement and tractor if children should enter the work area.
- Never allow children to climb or ride on the tractor or the implement at any time. There is no safe place on the machine for a rider. They may fall off and be run over or interfere with the operator's ability to control the machine.
- Never allow children to operate the power machine or implement, even under adult supervision.
- Use extreme caution when operating in reverse. Before the tractor starts to move, look down and behind to ensure the area is clear.

**SAFETY AT ALL TIMES**

Your best assurance against an accident or injury is the careful operation of all equipment. All operators, no matter their experience, should carefully read this manual and other related documents, or have the manuals read to them before operating the power machine and any Homestead Implements product.

- Thoroughly read the "Safety Information" section and understand all instructions noted on them.
- Never operate the equipment or implements while under the influence of drugs or alcohol.
- Operator should be familiar with all functions of the tractor and the attached implement.
- Ensure all correct guards and shields are in place and securely fastened before operating implement.
- Keep any and all bystanders away from attached equipment and the work area.
- Only start tractor from the driver's seat with the hydraulic controls in neutral.
- Never dismount from a moving tractor or leave the tractor running and unattended.
- Never allow anyone to stand between the tractor or the implement while backing up to the implement.
- Keep hands, feet, and any loose clothing away from power-driven parts.
- While transporting and operating equipment, be sure to watch for overhead objects as well as fences, trees, buildings, wires, etc.
- Do not make exceedingly tight turns as it may cause the hitched implement to ride up on the tractor's rear wheels.
- Store all implements in an area where children do not play. When needed, secure the attachment against falling or rolling with support blocks or wedges.



### **USING A SAFETY CHAIN**

- A safety chain will help the machine control the hitched implement should it separate from the tractor drawbar.
- Always hitch the implement to the machine towing it, do not use the safety chain alone to tow the implement.
- Use a chain with a strength rating equal to or greater than the complete gross weight of the towed implement.
- Attach the safety chain to the tractor drawbar support or other specified anchor location. Only allow enough slack in the chain to permit turning.

### **ALWAYS TRANSPORT SAFELY**

- Always comply with federal, state, and local laws when towing equipment.
- Be aware and avoid any contact with overhead utility lines or electrically charged conductors.
- Use towing vehicles and trailers of adequate size and capability only.
- Secure all equipment on trailer with appropriate tie downs and chains.
- Sudden and drastic braking can cause a towed trailer to swerve and upset. Reduce speed when in transit if the attached trailer does not have independent brakes.
- Always drive with the load on the end of leader arms low to the ground.
- Always drive straight up and down steep inclines with the heavy end of a tractor or implement with loader attachment on the “uphill” side.
- Always engage parking brake when stopped on an incline.
- **IMPORTANT:** Do not tow a load that is more than double the weight of the vehicle towing the load.

### **SAFE MAINTENANCE PRACTICES**

- Understand procedures before doing any work. Refer to Operator’s Manual for additional information and to confirm that any work done will not void the Homestead Implements Warranty.
- Work on a level surface in a clean dry area that is well-lit.
- Lower implement to the ground and follow the shutdown procedures before leaving the machine’s operator seat to perform any maintenance.
- Use properly grounded electrical outlets and tools and only use tools that are in good operating condition.
- Allow equipment to cool completely before performing any work on it.
- Do not work under any hydraulic supported equipment. Implement can settle, suddenly leak down, or be lowered accidentally. If it is necessary to work underneath the equipment, securely support it with stands and suitable blocking beforehand.
- Disconnect battery ground cable (-) before servicing or adjusting electrical systems or before welding on the implement.
- Replace parts on this implement with real Homestead Implements parts only. Do not alter this implement in a way which will adversely affect its performance.
- Remove buildup of grease, oil, or debris.
- Do not grease or oil implement while it is in operation.
- Inspect all parts and ensure that the parts are in good condition & installed properly.
- Always be sure that any material and waste from the repair and maintenance of the implement are properly collected and disposed of.
- Remove all tools and unused parts before operating the implement.
- Do not weld or torch on galvanized metal as it will release toxic and dangerous fumes.

**SEAT BELTS AND ROPS**

- Homestead Implements recommends the use of a CAB or a roll-over-protective-structures (ROPS) and seat belt in nearly all power machines. The combination of a CAB, ROPS, and a seat belt will reduce the risk of serious injury or death if the power machine should be upset.
- If ROPS is in the locked position, fasten seat belt snugly and securely to protect against serious injury or death from falling and machine overturn.

**BE PREPARED FOR EMERGENCIES**

- Be prepared for a fire, should one start.
- Always keep a first aid kit and a fire extinguisher handy.
- Keep a list of emergency numbers for a doctor, hospitals, fire department, and ambulances near or on your personal phone.

**KEEP RIDERS OFF MACHINERY**

- Never allow riders on the tractor or implement while in use.
- Riders can obstruct the operator's view and interfere with their ability to control the power machine.
- Riders can be struck by objects or be thrown from the equipment.
- Never use tractor or implements to lift or transport riders.

**USING PERSONAL PROTECTIVE EQUIPMENT (PPE)**

- Always wear protective equipment and clothing appropriate for the job such as safety shoes, earplugs, hard hats, and safety glasses.
- Clothing should fit snug without fringes and pull strings. This is to avoid dangerous entangling with moving parts.
- Operating equipment safely requires the operator's full attention. Avoid wearing headphones while operating and maintaining equipment.
- Prolonged exposure to excessive noise can cause hearing impairment and hearing loss. Wear suitable hearing protection such as earplugs or earmuffs.

**HIGH-PRESSURE FLUID HAZARDS**

- Fluid escaping under pressure can penetrate the skin and cause serious injury.
- Relieve all residual pressure from the hydraulic system before disconnecting hydraulic lines or performing any work on the system itself.
- Make sure all hydraulic fluid connections are tight and all lines are in good condition before applying any pressure to the system.
- **NEVER USE BODY PARTS** to check for suspected leaks. Always use a piece of paper or cardboard instead.
- Wear protective gloves and safety glasses before doing any work on hydraulic systems.
- **DO NOT DELAY REPORTING AN ACCIDENT.** If an accident occurs, see a doctor immediately. Any fluid injected into the skin or eyes must be treated immediately.

**UNDERGROUND UTILITIES**

- **DIG SAFE, CALL 811 (USA).**
- Always contact your local utility companies (electrical, telephone, gas, water, sewer, and others) before digging or using any implement so that they may mark the location of any underground services in the area.
- Always ask how close to the marked area you can work.



**PELIGRO**

**LEA EL INSTRUCTIVO**

Si No Lee Ingles Pida  
Ayuda a Alguien Que Si Lo  
Lea Para Que le Traduzca  
las Medidas de Seguridad.

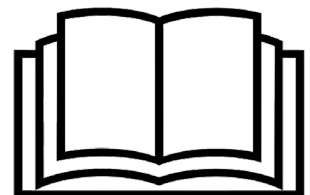

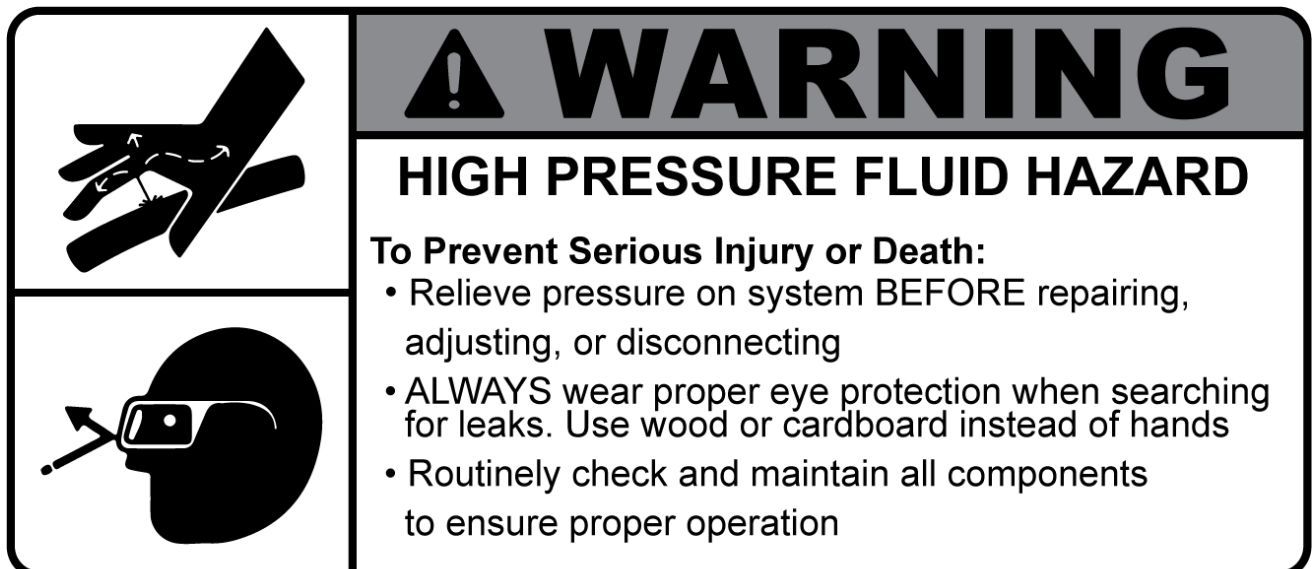

**Homestead Implements Pinnacle Series Bale Unroller**

**Technical Specification**

Model Numbers	HI-P-BU
Tractor Horsepower	20 to 50 hp (14.9-37.3 kw)
Overall Weight	260 lbs. (117.93 kg)
3-Point Hitch type	Category 1&2 Quick Hitch Compatible
Opening Width	66 1/4"
Closing Width	29 1/2"
Overall Length	63 1/4" (160.65 cm)
Overall Height	34 1/2" (87.63 cm)
Bale Size	4' to 5'
Maximum Load Capacity	1200 Lbs.
Hydraulic Cylinder	2"(5.1cm) x 6"(15.2cm) rod, 1 No's.
Maximum Pressure Rating	3000 psi
Hose Size	1/2"(12.7mm) ID with NPT Threading
Hose Pressure Rating	6100 psi

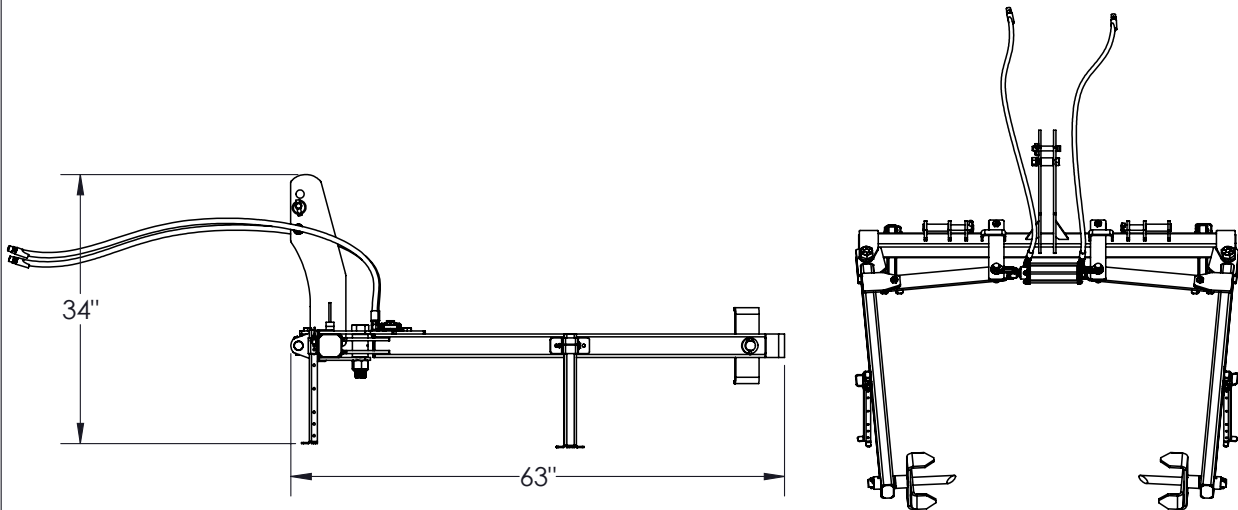

CUSTOMER APPROVAL :

DATE :



THIS DRAWING, WHICH CONTAINS PROPRIETARY INFORMATION, IS THE PROPERTY OF JAMESTOWN ADVANCED PRODUCTS CORPORATION. IT SHALL NOT BE REPRODUCED IN ANY MANNER NOR DISCLOSED TO THIRD PARTIES WITHOUT WRITTEN PERMISSION OF JAMESTOWN ADVANCED PRODUCTS CORPORATION.

DATE : 12/27/22

PRODUCT PART NUMBER : HI-P-BU

REV. NO.



PRODUCT DESCRIPTION :

**PINNACLE BALE UNROLLER**

2855 GIRTS ROAD  
JAMESTOWN, NY 14701

PHONE 833-625-0635 -- FAX 716-483-5398 -- WWW.HOMESTEADIMPLEMENTS.COM

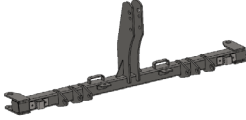
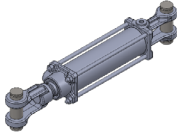
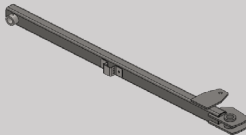
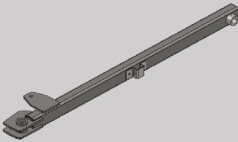
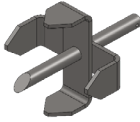

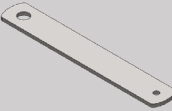
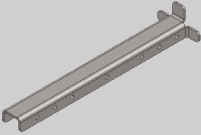
DESCRIPTION	PHOTO	DESCRIPTION	PHOTO
48" Hose Assembly, 3/8 Diameter End Connection: 1/2" NPT Fitting Working Pressure: 6100 psi/420 bar		3PT Link Quick Hitch Assembly	
2.00in. x 6.00in. 3000psi tie rod cylinder (20TH06.00-112)		Left Arm Assembly	
Right Arm Assembly		Spike Weldment Assembly	
Cylinder Top Plate and Sleeve Assembly		Cylinder Bottom Plate	
Implement Stand Leg			

**LEFT VIEW**

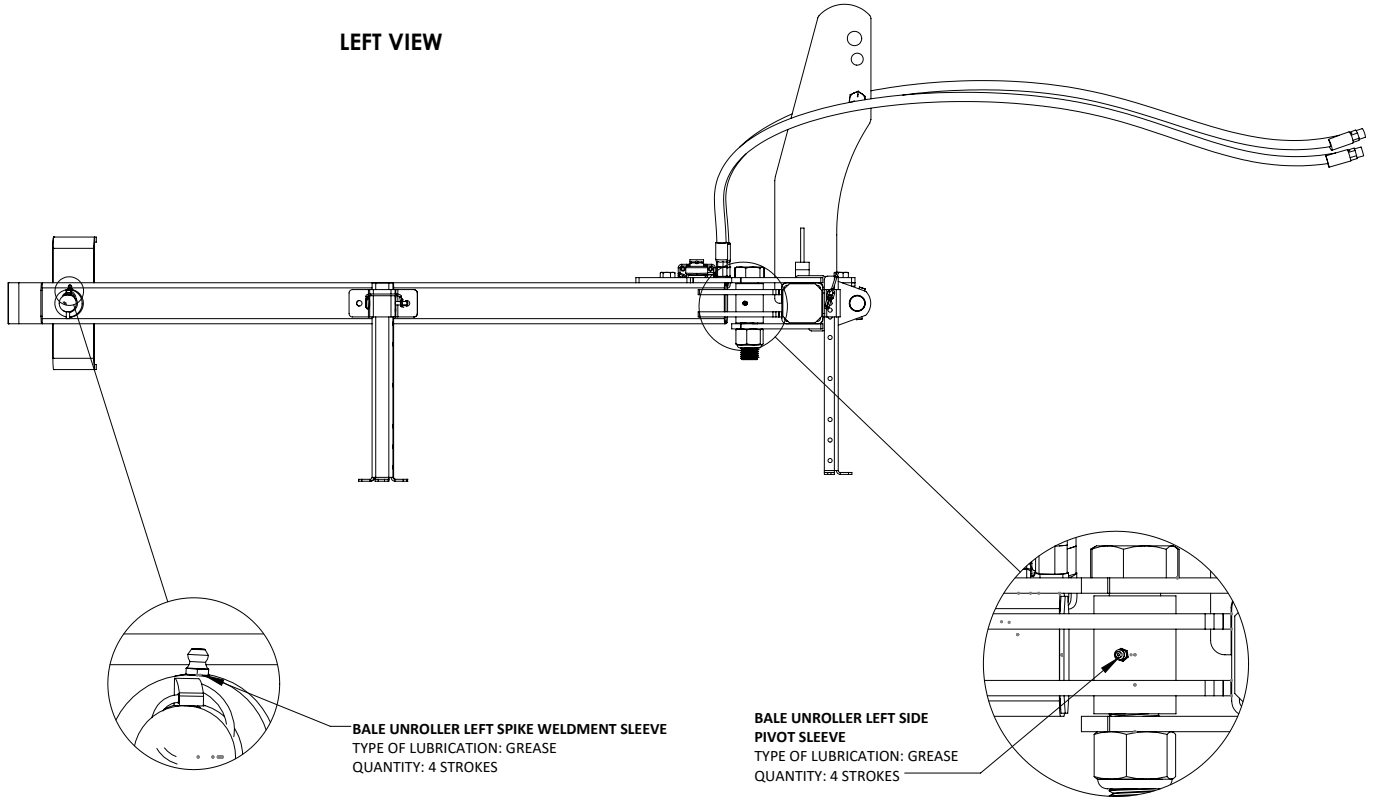

**RIGHT VIEW**

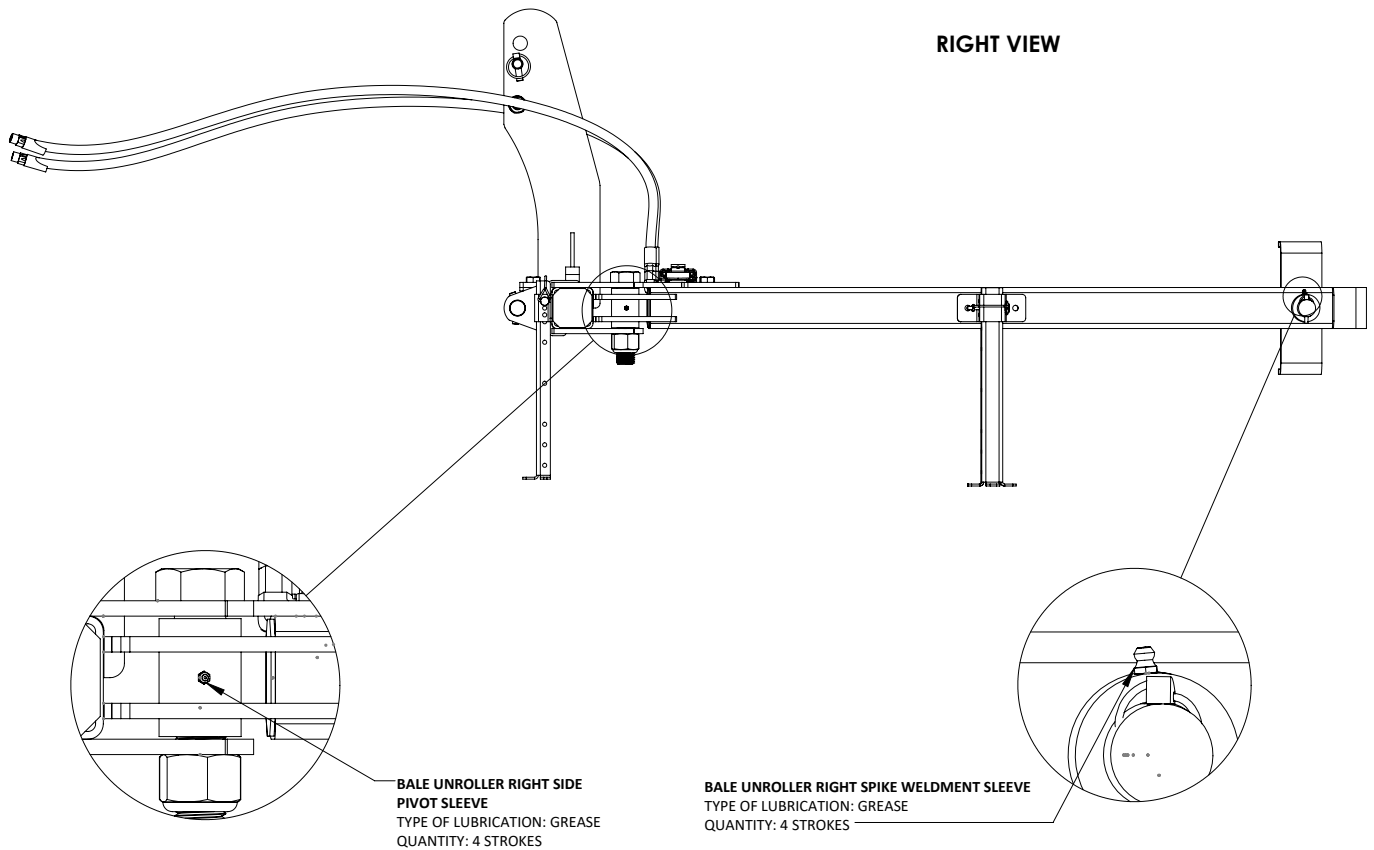

<b>Torque Chart For Metric Bolts</b>				
<b>Bolt Diameter (MM)</b>	<b>Tightening Torque</b>			
	<b>Class 8.8</b>		<b>Class 10.9</b>	
	<b>ft lbs</b>	<b>N-m</b>	<b>ft lbs</b>	<b>N-m</b>
5	7	9	9	12
6	12	16	16	22
8	30	41	40	54
10	55	75	75	102
12	100	136	135	183
14	160	217	215	292
16	245	332	335	454
20	480	651	650	881

<b>Torque Chart For Imperial Bolts</b>					
<b>Bolt Size</b>	<b>Thread Per inches</b>	<b>Tightening Torque</b>			
		<b>ASTM A449 / SAE Grade 5*</b>		<b>ASTM A354- BD / SAE Grade 8*</b>	
		<b>ft lbs</b>	<b>N-m</b>	<b>ft lbs</b>	<b>N-m</b>
1/4	20	8	11	9	12
5/16	18	17	23	18	25
3/8	16	31	42	32	44
7/16	14	49	66	52	70
1/2	13	75	102	79	107
9/16	12	109	148	114	154
5/8	11	150	203	156	212
3/4	10	266	361	277	376
7/8	9	429	582	447	606
1	8	644	873	670	909
1 1/8	7	794	1077	949	1,287
1 1/4	7	1,120	1519	1383	1,875
1 3/8	6	1,469	1992	1757	2,382
1 1/2	6	1,950	2644	2331	3,161
1 3/4	5	2,286	3099	3678	4,988
2	4 1/2	3,438	4661	5531	7,500



---

---

# TERMS & CONDITIONS

## Product Warranty to the Original Purchaser

All Homestead Implements products carry a 12-month limited warranty against defects in materials and workmanship under normal use. This includes all components of each implement – including gearbox assemblies, PTO shafts, and hydraulic cylinders. The warranty does not cover components of the implements that are declared wear items. **This includes but is not limited to:** shoes, cutting edges, blades, tires, tines, hydraulic hoses, seals, slip clutches, and any other component of the implement that is used during normal operation.

This warranty becomes active upon the date of delivery. If a product or component fails during the warranty period, coverage is limited to repair by the manufacturer or replacement of the defective part, at the discretion of the manufacturer. This Warranty does not apply to any part or product which in Homestead Implements judgment appears to have been damaged through misuse, accident, or lack of proper maintenance or care. Misuse also specifically includes the buyer's failure to properly monitor and maintain correct oil levels, grease points, and driveline shafts.

The above warranties are valid only if the product: a) is assembled and installed according to manufacturer's specifications and instructions; b) has been properly maintained according to manufacturer's instructions; c) has not been altered by the addition or deletion of parts, or modified in any other manner; d) has not been subject to misuse, vandalism, negligence or damage by accident; e) buyer shall be required to provide the seller with prompt written notice and photo evidence if required; f) buyer shall comply with such instructions as the seller shall provide concerning the return of the defective product; g) product(s) has not been shipped outside the Continental U.S. prior to claim.

Homestead Implements warranties **do not cover:** a) vandalism; b) damage caused by incorrect assembly, installation or application (use); c) natural or man-made disasters; d) cosmetic changes in the product due to weathering, including paint fading or peeling; e) scratches, dents or marring caused by normal use or public exposure; f) damage caused by seasonal climatic differences or lack of proper maintenance; g) loss or damage due to personal transport or hauling; h) damage to components of the implement declared to be a wear-item.

Warranty claims must be filed within the Warranty period and must include a copy of the original invoice or purchase order. Furthermore, this Warranty should not be interpreted to render Homestead Implements liable for damages of any kind, direct, consequential, or to property. This Warranty does not extend to any expense or loss for labor, rental machinery, loss of crops, supplies, or for any other reason.

Except as specifically stated herein, all warranties (express or implied), including but not limited to any implied warranty of merchantability or fitness for a particular purpose, are hereby excluded. This warranty excludes any liability other than expressly stated, herein, including, but not limited to, any incidental or consequential damages.

**No Warranty to any purchaser other than the original purchaser.**

## Return Policy & Warranty Claims

To return a product or to make a Warranty claim please contact a customer service representative at 833-625-0635 to receive a Returned Merchandise Authorization (RMA) number. This number must be



placed on the outside of the returned product(s). Returns/claims without an RMA number will be subject to a 25% restocking fee, providing the criteria below have been met\*.

Returns within 30 days of receipt are exchanged or the purchase is refunded completely. Returns after 30 days from the invoice date with an RMA number are subject to a 25% restocking fee. No returns accepted after 60 days.

\*For returns, all parts must be returned in the original package and not be damaged and must be in a condition that justifies resale. Returns that are incomplete unit(s) will be billed for the missing parts before any credit is issued. Credit will only be issued after inspection by our staff. **All returns must be sent freight prepaid. We will not accept any package shipped C.O.D.**

Warranty claims must be shipped with all original parts included should Homestead Implements confirm culpability for damage on the product. Homestead Implements will examine each Warranty claim individually and decide whether to repair or replace the item. If return shipping is required, **it must be sent freight prepaid. We will not accept any package shipped C.O.D.**

Homestead Implements will cover any return shipping on replacement or repaired parts.

Orders canceled after product ships are subject to freight charges and or restocking charges. Freight charges will be applied based on the actual costs, to and from, the shipping location and the original purchaser **only within the Continental U.S.** Canceling or returning item(s) results in loss of free freight eligibility. You will be responsible for all freight charges.

Returned items and Warranty claims may be shipped to **Jamestown Advanced Products Corp., 2855 Girts Road, Jamestown, NY 14701**

### Damages

Damages are to be reported to Jamestown Advanced Products as soon as possible, or no later than five business days after receipt of the shipment per the signed bill of lading. Should the product(s) become damaged during transit it is the customer's responsibility to notify the carrier's agent and the carrier's agent acknowledgment of such damage noted on the bill of lading. The customer is then to immediately notify Jamestown Advanced Products Corp of such damage and a claim will be filed.

Homestead Implements, and Jamestown Advanced Products, will not be responsible for charges incurred per the customer's request for outside service contractors to repair/alter/check any of our products without prior written approval.

### Additional Information

[www.homesteadimplements.com](http://www.homesteadimplements.com)

**Customer Service Representative: 833-625-0635**

Homestead Implements/Jamestown Advanced Products

2855 Girts Road, Jamestown, NY 14701



