

Homestead Implements Independence Series Box Blade

Technical Specification

Model Numbers	HI-I-BX-48	HI-I-BX-60	HI-I-BX-72
Working Width	48" (1.21m)	60" (1.52m)	72" (1.82m)
Height and Length	33.25" (0.84 m) Height x 33.75" (0.86 m) Length		
Capacity	6.22 cu. ft. (0.17 cu. m)	7.77 cu. ft. (0.22 cu. m)	9.32 cu. ft. (0.26 cu. m)
Weight	271 lbs (123 kg)	319 lbs (145 kg)	365 lbs (165.5 kg)
Number of Shanks	4	5	6
Shank Material	3/4" x 2.5" x 16" (19 mm x 63 mm x 406 mm) heat treated spring steel		
Vertical Shank Positions	3 Positions (2 1/4" (5.7 cm) above scraper end plates; 1/4" (6 mm) and 2 3/4" (7 cm) below scraper end plates		
Shank Tip Construction	Replaceable heat treated dimpled-on tips		
Shank Beam	4" x 4" x 1/4" (10.2cm x 10.2cmx 6.4mm) Square Tubing		
Moldboard	A-36 grade moldboard - 13 3/4"(35 cm) Tall		
Side Panels	1/4"(6.3mm) Thick x 20"(50.8 cm) Long x 12-3/4"(32.4 cm) Tall		
Depth of Box	17 1/2" (44.5cm)		
Blade and Box Reinforcement	Welded braces to rear of bucket between the cutting edges		
Number of Cutting Blades	2 Blades		
Cutting Blade Properties and Size	High-carbon steel, heat-treated cutting edges 3/8" x 6" (0.95 cm x 15.2 cm)		
Cutting Blade Function	Reversible and replaceable		
Maximum H.P. Rating	30 HP (22.37 kw)		
A-Frame Material	3/8" x 2.5" (0.95 cm x 6.35 cm), A-36		
3-Point Hitch Type	Category 1 Quick-Hitch compatible, also equipped with 7/8" (2.2cm) lower hitch pins and 1.25" (3.1cm) upper hitch pin		

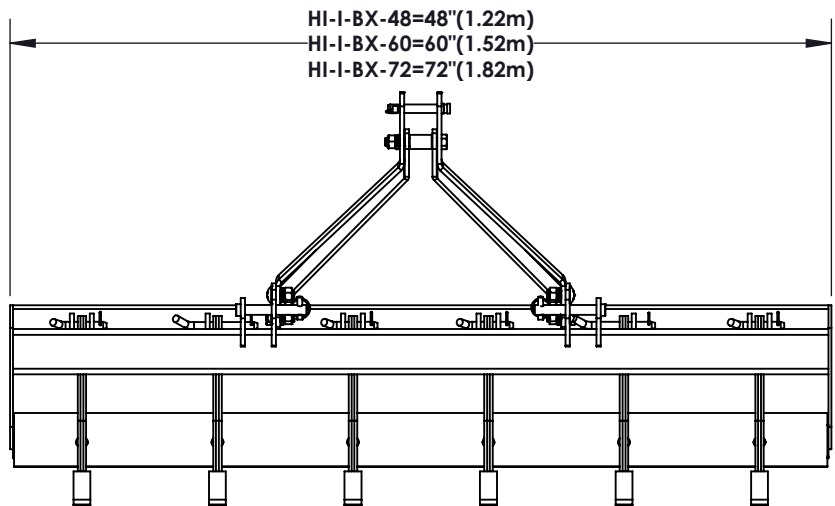
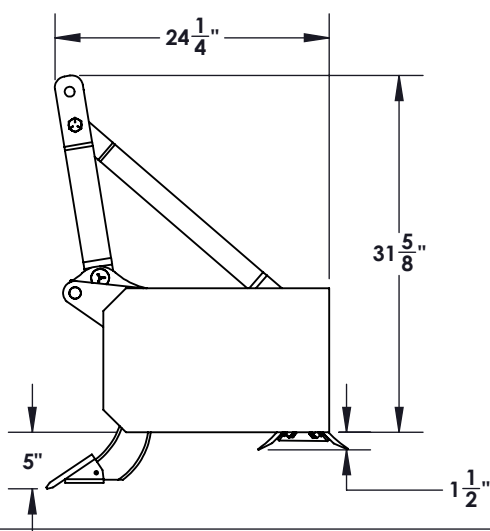

CUSTOMER APPROVAL :

DATE :



THIS DRAWING, WHICH CONTAINS PROPRIETARY INFORMATION, IS THE PROPERTY OF JAMESTOWN ADVANCED PRODUCTS CORPORATION. IT SHALL NOT BE REPRODUCED IN ANY MANNER NOR DISCLOSED TO THIRD PARTIES WITHOUT WRITTEN PERMISSION OF JAMESTOWN ADVANCED PRODUCTS CORPORATION.

DATE : 04/19/2022

PRODUCT PART NUMBER : HI-I-BX

REV. NO.

PRODUCT DESCRIPTION :

INDEPENDENCE BOX BLADE

2855 GIRTS ROAD
JAMESTOWN, NY 14701