

Homestead Implements Independence Series Land Plane

Technical Specification

Model Numbers	HI-I-LPS-48	HI-I-LPS-60
Working Width	48" (1.22 m)	60" (1.52 m)
Overall Width	52 3/4" (1.33 m)	64 3/4" (1.63 m)
Number of Scarifier Shanks	4	4
Maximum H.P. Rating	30 HP (22.37 kw)	
Total Weight w/ Shanks	336 lbs (152.47 kg)	374 lbs (169.64 kg)
Overall Length	44" (1.12 m)	
Overall Height	31" (80 cm)	
Side Panel Height	12 1/2" (31.8 cm)	
Side Panel Length	39" (0.99 m)	
Side Panel Thickness	1/4" (25.4mm) thick side panels with replaceable skid shoe underneath.	
Front Main Beam & Scarifier Support	4"x 4" x 1/4" (10.2 cm x 10.2 cm x 0.6 cm) wall tubing.	
Rear Beam Construction	2"x 2" x 3/16" (5.1 cm x 5.1 cm x 0.5 cm) wall tubing.	
Skid Shoe Dimension	1/4" (6.35 mm) Thick x 3" (7.6 cm) wide x 39" (0.99 m) long.	
Scarifier Shank Construction	3/4" x 2.5" x 16" (19 mm x 63 mm x 406 mm) Replaceable heat treated dimpled-on tips	
Cutting Edges	two High carbon steel, heat treated cutting edges 3/8" x 6" (0.95 cm x 15.2 cm)	
Cutting Edge Placement	Two parallel cutting edges placed at 5 degree angle leaving 17.5" (44.6cm) space between them through all.	
Shank Adjustments	2 1/4" (5.7 cm) above scraper end plates 1/4" (6 mm) and 2 3/4" (7 cm) below scraper end plates	

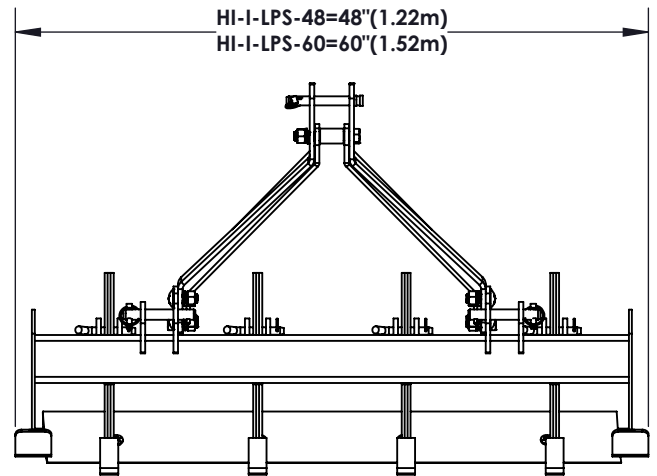
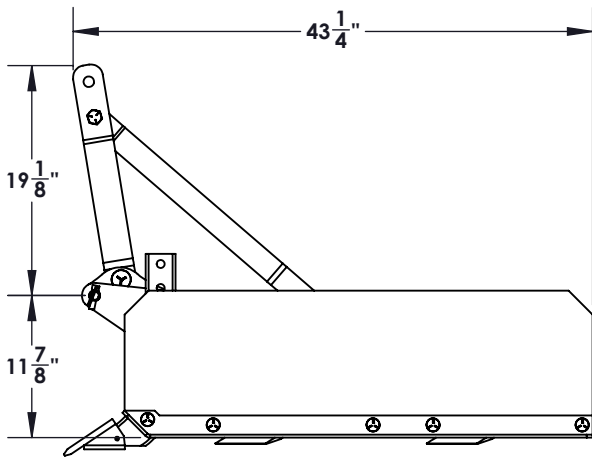

CUSTOMER APPROVAL :

DATE :



THIS DRAWING, WHICH CONTAINS PROPRIETARY INFORMATION, IS THE PROPERTY OF JAMESTOWN ADVANCED PRODUCTS CORPORATION. IT SHALL NOT BE REPRODUCED IN ANY MANNER NOR DISCLOSED TO THIRD PARTIES WITHOUT WRITTEN PERMISSION OF JAMESTOWN ADVANCED PRODUCTS CORPORATION.

DATE : **03/28/2023**

PRODUCT PART NUMBER : **HI-I-LPS**

REV. NO. **1**

PRODUCT DESCRIPTION :

INDEPENDENCE LAND PLANE

2855 GIRTS ROAD
JAMESTOWN, NY 14701