

Homestead Implements Independence Series Grapple for Sub-Compact Tractors

Technical Specification

Model Numbers	HI-I-SCG-54
Weight	190 lbs (86.2 kg)
Overall Width	54" (1.37 m)
Closed Height	30" (0.76 m)
Jaw Opening	29" (0.74 m)
Number of Teeth	7 Bottom & 6 Top
Teeth Spacing	8 23/32" (22.1 cm) on bottom teeth and 9 1/2" (24.1 cm) on the top teeth
Tooth Thickness and Material	1/4" (6.35 mm) HARDOX® 450
Working Length of Teeth	8 7/8" (22.5cm)
Hydraulic Cylinder	2" (5.1cm) x 4"(10.2cm) x 1 1/8"(2.8cm) Rod, 2 Nos.
Maximum Pressure Rating	2500 PSI
Hose Size and Connector	3/8" (9.5mm) ID with JIC flare fitting
Hose Size	1/2" (12.7mm) ID with NPT threading
Hose Pressure Rating	6000 PSI
Hitch Attachment	Universal Quick-Attach (SSQA)
Recommended Tractor Specifications	Up to 25 HP & less than 1,000 lbs lift capacity

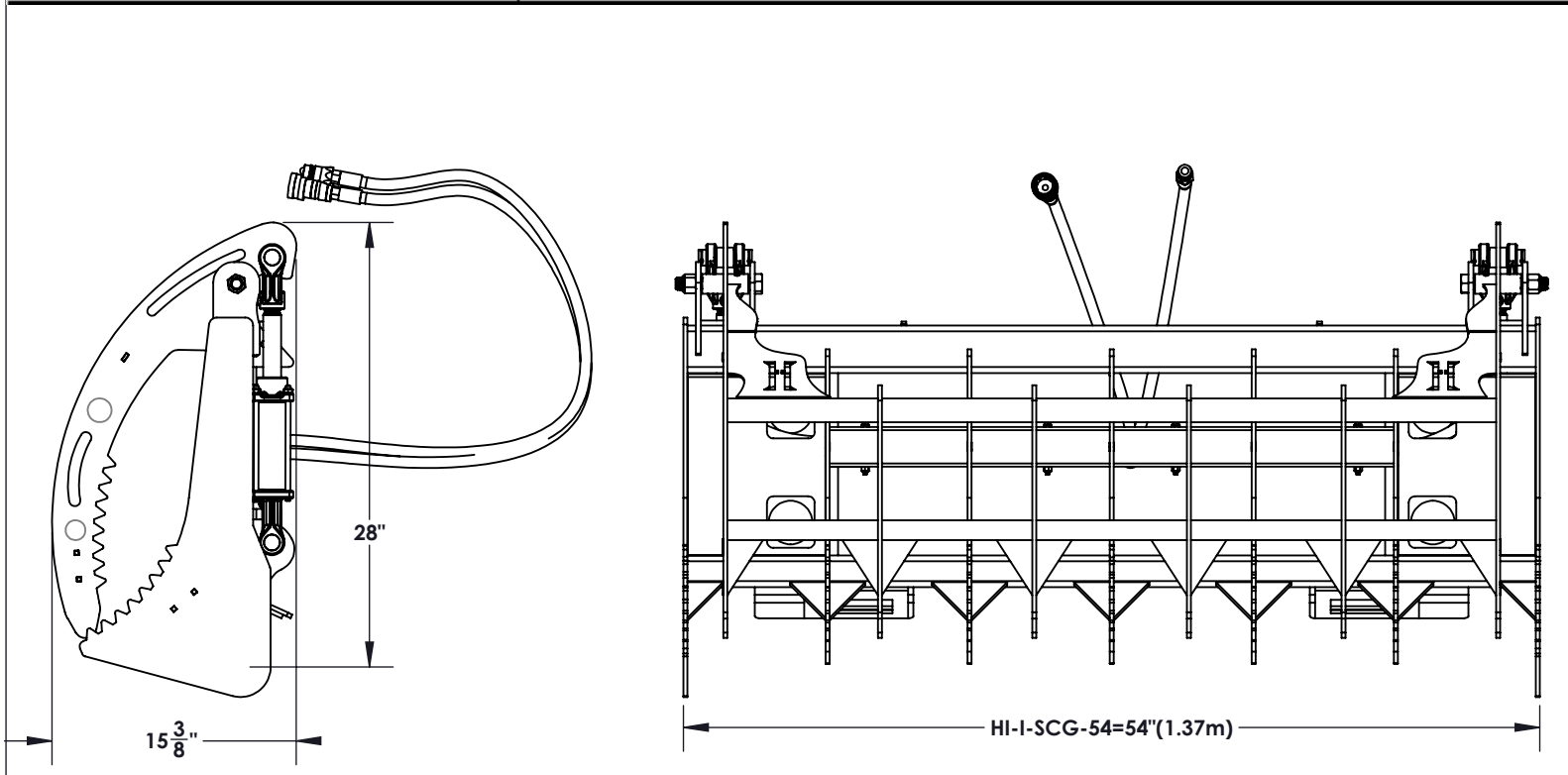

CUSTOMER APPROVAL :

DATE :



THIS DRAWING, WHICH CONTAINS PROPRIETARY INFORMATION, IS THE PROPERTY OF JAMESTOWN ADVANCED PRODUCTS CORPORATION. IT SHALL NOT BE REPRODUCED IN ANY MANNER NOR DISCLOSED TO THIRD PARTIES WITHOUT WRITTEN PERMISSION OF JAMESTOWN ADVANCED PRODUCTS CORPORATION.

DATE :04/19/2022

PRODUCT PART NUMBER : **HI-I-SCG**

REV. NO.

PRODUCT DESCRIPTION :

INDEPENDENCE SUB-COMPACT GRAPPLE

2855 GIRTS ROAD
JAMESTOWN, NY 14701