

Homestead Implements Pinnacle Series Box Blade V2

Technical Specification

Model Numbers	HI-P-BX-60	HI-P-BX-72	HI-P-BX-84
Working Width	60" (1.52m)	72" (1.82m)	84"(2.13m)
Capacity	12.97 cu. ft. (0.37 cu. m)	15.75 cu. ft. (0.45 cu. m)	18.53 cu. ft. (0.52 cu. m)
Weight	412 lbs (187 kg)	473 lbs (215 kg)	528 lbs (240 kg)
Number of Shanks	5	6	7
Shank Material	3/4" x 2.5" x 16" (19 mm x 63 mm x 458 mm) heat treated spring steel		
Vertical Shank Positions	4- positions		
Shank Tip Construction	Replaceable heat treated dimpled-on tips		
Shank Beam	4" x 3" x 3/16" (10.2cm x 7.6cmx 4.8mm) Square Tubing with 3/8" x 3" long shank reinforcements		
Moldboard	A-36 grade moldboard - 17 1/4"(43.8cm) Height and 3/16"(4.5mm) Thick		
Side Panels	1/4"(6.3mm) thick x 23.5"(59.7cm)deep x 16"(40.6cm) height		
Depth of Bucket	22 3/4" (57.7cm)		
Number of Cutting Blades	2 Blades		
Cutting Blade Properties and Size	High carbon steel, heat treated cutting edges 1/2" x 6" (1.2cm x 15.2cm)		
Cutting Blade Function	Reversible and replaceable		
Maximum H.P. Rating	55 HP (41 kw)		
A-Frame Material	3/8" (1.2cm) Thick, A-36		
3-Point Hitch Type	Cat. 1 Quick-Hitch Compatible	Category 1 & 2 Quick-Hitch Compatible	

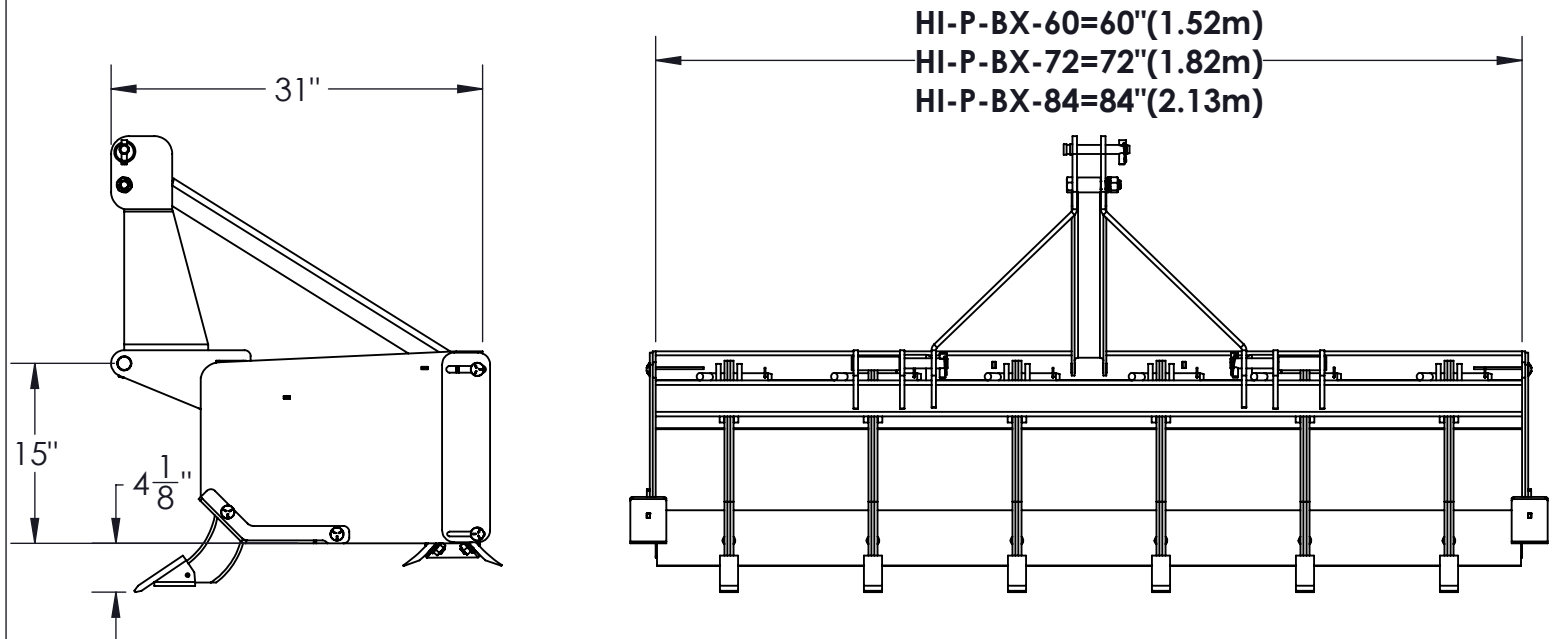

THIS DRAWING, WHICH CONTAINS PROPRIETARY INFORMATION, IS THE PROPERTY OF JAMESTOWN ADVANCED PRODUCTS CORPORATION. IT SHALL NOT BE REPRODUCED IN ANY MANNER NOR DISCLOSED TO THIRD PARTIES WITHOUT WRITTEN PERMISSION OF JAMESTOWN ADVANCED PRODUCTS CORPORATION.

DATE : 08/29/2022

PRODUCT PART NUMBER : HI-P-BX

REV. NO. V2.0

**PRODUCT DESCRIPTION :
PINNACLE BOX BLADE**

2855 GIRTS ROAD
JAMESTOWN, NY 14701