

Homestead Implements Pinnacle Series 3-PT Post Hole Digger

Technical Specification

Model Number	HI-P-PHD-FEL
Tractor Horsepower Range	18 to 50 HP
Weight w/o Auger	173 lbs (64.5 kg)
Driveline (PTO Shaft)	Series 4 Shearbolt Protection
Maximum Operating PTO Speed	540 RPM
Gearbox	1 1/4" (3.18 cm) circular input shaft, 3.5:1 Ratio
Gearbox Oil Capacity & Type	5.28 Pints (2.5 L) of SAE80W-90 EP oil
Output Shaft	2" (5.1 cm) O.D. Round
3-Point Hitch Cat.	Cat. I
Boom	2 3/8" (6.03 cm) O.D.
Yoke	2 3/8" (6.03 cm) O.D.

Auger

Auger Feature	Double start, single carry flight configuration, shallow flight pitch		
Auger Flighting Thickness	13/64" (5 mm)		
Drilling Condition	General		
Auger Teeth	Forged, individually replaceable		
Auger Diameter	6" (15.2 cm)	9" (22.9 cm)	12" (30.5 cm)
Dirt Auger Weights	33 lbs. (15 kg)	43 lbs. (19.5 kg)	57 lbs. (25.85 kg)
Number of Teeth	2	2	4
Auger Pipe	2 3/8" OD (6.03 cm) ID	2 3/8" OD (6.03 cm) ID	2 3/8" OD (6.03 cm) ID
Auger Pilot Drive	Fish Point cast steel / Standard Cast Steel	Fish Point cast steel / Standard Cast Steel	Fish Point cast steel / Standard Cast Steel
Auger Length	48"	48"	48"

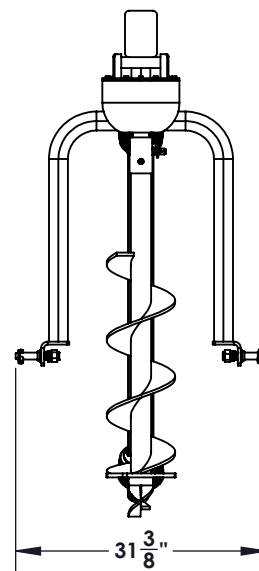
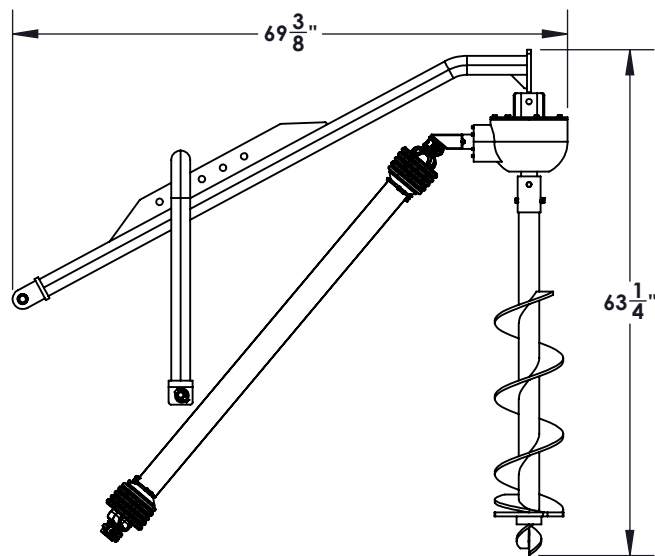

CUSTOMER APPROVAL :

DATE :



THIS DRAWING, WHICH CONTAINS PROPRIETARY INFORMATION, IS THE PROPERTY OF JAMESTOWN ADVANCED PRODUCTS CORPORATION. IT SHALL NOT BE REPRODUCED IN ANY MANNER NOR DISCLOSED TO THIRD PARTIES WITHOUT WRITTEN PERMISSION OF JAMESTOWN ADVANCED PRODUCTS CORPORATION.

DATE :04/20/2022

PRODUCT PART NUMBER : HI-P-PHD-3PT

REV. NO.

PRODUCT DESCRIPTION :
PINNACLE-POST HOLE DIGGER-3POINT HITCH

2855 GIRTS ROAD
JAMESTOWN, NY 14701