

# Homestead Implements Pinnacle Series Front Loader Hydraulic Auger Drive

## Technical Specification

<b>Model Number</b>	<b>HI-P-PHD-FEL</b>
<b>Hydraulic Requirements</b>	6-16 gpm (22.7 - 60.56 Lpm) @ 1500 to 3500 psi (10.3 to 24.1 MPa)
<b>Auger Drive Weight</b>	105 lbs. (47.62 kg)
<b>Auger Drive</b>	Hydraulic
<b>Gearbox</b>	Compact high torque hydraulically driven gearbox, reversible
<b>Gearbox Output Shaft</b>	2" (5.1 cm) Hex
<b>Hydraulic Hose Kits</b>	87" long hoses with quick couplers
<b>Gearbox Oil</b>	ISO 320 Mineral oil
<b>Gearbox Oil Capacity</b>	20 oz. (591 ml)

## Quick-Attach Auger Mount (SSQA)

<b>Quick-Attach Auger Mounts</b>	Universal Quick-Attach Hitch (SSQA)
<b>Overall Length</b>	45.5"
<b>Overall Height</b>	20.15"
<b>Overall Width</b>	11.5"
<b>Weight</b>	110 lbs.
<b>Front and Rear Beam Construction</b>	3" x 3" x 3/16" (7.5cm x 7.5cm x 4.76mm) Square Tubing
<b>Frame Construction</b>	1/4" Plates construction with 3/8" quick attach mounting plates

## Auger

<b>Auger Feature</b>	Double start, single carry flight configuration, shallow flight pitch	
<b>Auger Flighting Thickness</b>	5/16" (8 mm)	
<b>Drilling Condition</b>	General	
<b>Auger teeth</b>	Forged, individually replaceable	
<b>Auger Diameter</b>	6"	9"
<b>Dirt Auger Weights</b>	51 lbs. (23.2 kg)	71 lbs. (32.2 kg)
<b>Number of Teeth</b>	2	4
<b>Auger Pipe</b>	2 3/8" OD	3" OD
<b>Auger Pilot Drive</b>	Fish Point cast steel	
<b>Auger Length</b>	48"	

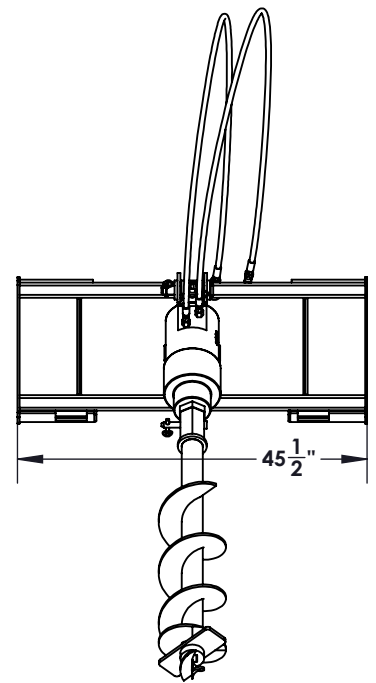
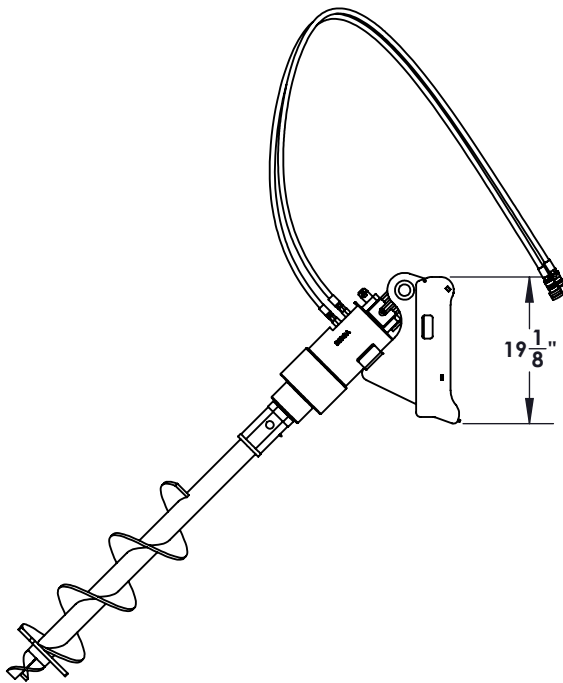

CUSTOMER APPROVAL :

DATE :



THIS DRAWING, WHICH CONTAINS PROPRIETARY INFORMATION, IS THE PROPERTY OF JAMESTOWN ADVANCED PRODUCTS CORPORATION. IT SHALL NOT BE REPRODUCED IN ANY MANNER NOR DISCLOSED TO THIRD PARTIES WITHOUT WRITTEN PERMISSION OF JAMESTOWN ADVANCED PRODUCTS CORPORATION.

DATE : 04/20/2022

PRODUCT PART NUMBER : HI-P-PHD-FEL

REV. NO.

PRODUCT DESCRIPTION :  
**PINNACLE-POST HOLE DIGGER-FRONT END LOADER**

2855 GIRTS ROAD  
JAMESTOWN, NY 14701